

CAST STEEL SWING CHECK VALVES- BS 1868, API-6D, ASME B16.34

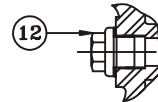
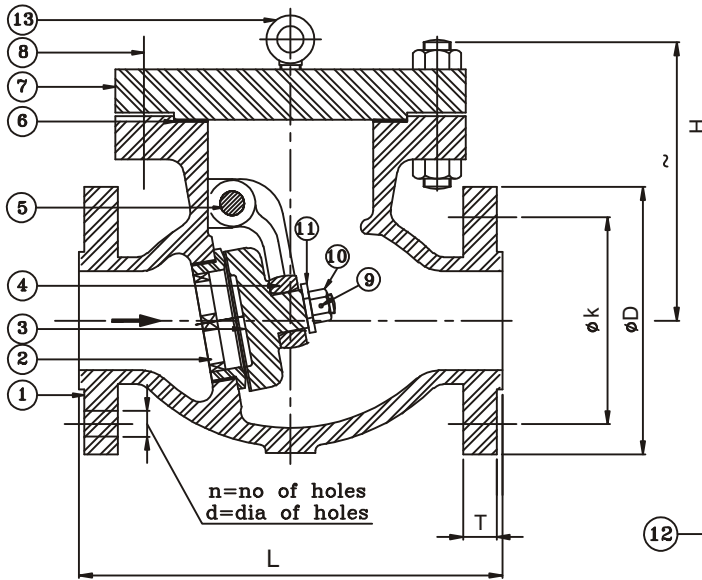

n=No. of holes
Ød=Dia. of holes

STANDARD MATERIAL COMBINATION

P. NO.	PART DESCRIPTION	Carbon steel to ASTM		Alloy steel to ASTM					Stainless steel to ASTM			
		Type WCB	Type LCB	Type WC1	Type WC6	Type WC9	Type C5	Type C12	Type CF8	Type CF8M	Type CF3	Type CF3M
1	BODY	A216 WCB	A352 LCB	A217 WC1	A217 WC6	A217 WC9	A217 C5	A217 C12	A351 CF8	A351 CF8M	A351 CF3	A351 CF3M
2	BODY SEAT RING	A216 WCB	A352 LCB	A217 WC1	A217 WC6	A217 WC9	A217 C5	A217 C12	A351 CF8	A351 CF8M	A351 CF3	A351 CF3M
3	DISC	AS PER TRIM MATERIAL COMBINATION										
4	HING	A216 WCB	A352 LCB	A217 WC1	A217 WC6	A217 WC9	A217 C5	A217 C12	A351 CF8	A351 CF8M	A351 CF3	A351 CF3M
6	GASKET	Stainless Steel + Graphoil										
7	BONNET	A216 WCB	A352 LCB	A217 WC1	A217 WC6	A217 WC9	A217 C5	A217 C12	A351 CF8	A351 CF8M	A351 CF3	A351 CF3M
8	STUD & NUT	A193 B7 A194 2H	A720 L7 A194 Gr4	A193 B16 A194 Gr4	A193 B16 A194 Gr4	A193 B16 A194 Gr4	A193 B16 A194 Gr4	A193 B16 A194 Gr4	A193 B8 A194 Gr8	A193 B8 A194 Gr8	A193 B8 A194 Gr8	A193 B8 A194 Gr8
10	DISC NUT	Stainless Steel										
12	SIDE PLUG	Stainless Steel										
13	LIFTING HOOK	Carbon Steel										

NOTE: The above data is subject to change without notice due to our continuing product improvement program.

TRIM MATERIAL COMBINATION (ON REQUEST)

Trim No.	Seat Ring Face	Wedge Seat Face	Stem	Backseat Bush	Lantern Ring
1	F6a/13%Cr.	F6a/13%Cr.	F6a/AISI410	F6a/AISI410	F6a/AISI410
2	F304	F304	F304/AISI304	F304/AISI304	F304/AISI304
5	STELLITE	STELLITE	F6a/AISI410	F6a/AISI410	F6a/AISI410
8	STELLITE	F6a/13%Cr.	F6a/AISI410	F6a/AISI410	F6a/AISI410
9	MONEL	MONEL	MONEL	MONEL	MONEL
10	F316	F316	F316/AIS1316	F316/AIS1316	F316/AIS1316
12	316+STELLITE	316	F316/AIS1316	F316/AIS1316	F316/AIS1316
13	ALLOY 20	ALLOY 20	ALLOY 20	ALLOY 20	ALLOY 20

NOTE: The above data is subject to change without notice due to our continuing product improvement program.

CAST STEEL SWING CHECK VALVES- BS 1868, API-6D

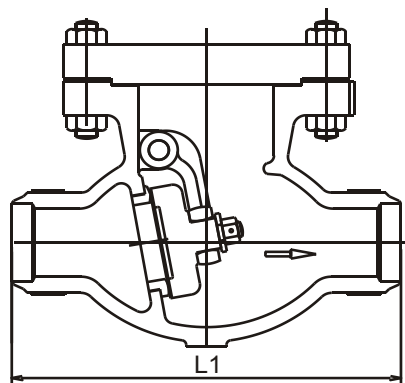

BUTT WELDED ENDS (BWE)

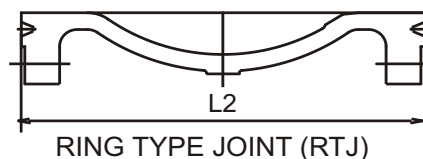

RING TYPE JOINT (RTJ)

NOTE:

(1) CLASS 150 & 300 FLANGES ARE FURNISHED WITH 2mm RAISED FACE

(f) CLASS 600 & ABOVE FLANGES ARE FURNISHED WITH 7mm RAISED FACE (f) WHICH IS ADDITIONAL TO THE FLANGE THICKNESS (T)

•All dimensions in mm

DIMENSIONAL DATA CLASS - 150

DN	40	50	65	80	100	125	150	200	250	300	350	400	450	500	600
NPS	1 ½	2	2 ½	3	4	5	6	8	10	12	14	16	18	20	24
L	165	203	216	241	292	330	356	495	622	698	787	864	978	978	1295
L1	165	203	216	241	292	330	356	495	622	698	787	864	978	978	1295
L2	178	216	229	254	305	343	369	508	635	711	800	877	991	991	1308
D	125	150	180	190	230	255	280	345	405	485	515	595	635	300	815
T	12.7	14.3	15.9	17.5	22.3	22.3	23.9	27	28.6	30.2	33.4	35	38.1	41.3	46.1
K(PCD)	98.4	121.7	139.7	152.4	190.5	215.9	241.3	298.5	362	431.8	476.2	539.8	577.8	635	749.3
n	04	04	04	04	08	08	08	08	12	12	12	16	16	20	20
d	15.9	19	19	19	19	22.2	22.2	22.2	25.4	25.4	28.6	28.6	31.8	31.8	34.9
H	130	140	165	168	190	228	230	261	345	356	425	468	540	600	680
Æb	38	51	64	76	102	127	152	203	254	300	337	387	438	489	591
Aprox.Wt.à	12	17	27.1	34.5	56	76	93	159	277	580	487	715	905	986	1400

DIMENSIONAL DATA CLASS - 300

DN	40	50	65	80	100	125	150	200	250	300	350	400	450	500	600
NPS	1 ½	2	2 ½	3	4	5	6	8	10	12	14	16	18	20	24
L	241	267	292	318	356	400	444	533	622	711	838	864	978	1016	1346
L1	241	267	292	318	356	400	444	533	622	711	838	864	978	1016	1346
L2	254	283	308	334	372	416	460	549	638	727	854	880	994	1035	1368
D	155	165	190	210	255	280	320	380	445	520	585	650	710	775	915
T	19.1	20.7	23.9	27	30.2	33.4	35	39.7	46.1	49.3	54.4	55.6	58.8	62	68.3
K (PCD)	114.3	127	149.2	168.3	200	235	269.9	330.2	387.3	450.8	514.4	571.5	628.6	685.3	813
n	04	08	08	08	08	08	12	12	16	16	20	20	24	24	24
d	22.2	19	22.2	22.2	22.2	22.2	22.2	25.4	28.6	31.8	31.8	35	35	35	41
H	145	170	182	200	216	320	275	332	385	455	520	785	785	867	1026
Æb	38	51	64	76	102	127	152	203	254	305	337	387	432	483	584
Aprox.Wt.à	22.3	29	51.1	54.5	75	161.5	161.5	240	380	584	729	865	1158	1580	1975

NOTE: Flanges as per ASME B16.5. Butt Weld Ends as per ANSI B 16.25.

The above data is subject to change without notice due to our continuing product improvement program. (©WEIGHT GIVEN IN KGS)



CAST STEEL SWING CHECK VALVES- BS 1868, API-6D

•All dimensions in mm

DIMENSIONAL DATA CLASS-600

DN	40	50	65	80	100	125	150	200	250	300	350	400	450	500	600
NPS	1 ½	2	2 ½	3	4	5	6	8	10	12	14	16	18	20	24
L	241	292	330	356	432	508	559	660	787	838	889	991	1092	1194	1397
L1	241	292	330	356	432	508	559	660	787	838	889	991	1092	1194	1397
L2	241	295	333	359	435	511	562	663	790	841	892	994	1095	1200	1419
kD	156	165	190	210	273	330	356	419	508	559	603	685.8	743	812.8	940
T	22.3	25.4	28.6	31.8	38.1	44.4	47.6	55.6	63.5	66.7	69.9	76.2	82.6	88.9	101.6
K(PCD)	114.3	127	149.2	168.3	215.9	266.7	292.1	349.2	431.8	489	527	603.3	654	724	838.2
n	04	08	08	08	08	08	12	12	16	20	20	20	20	24	24
kd	22.2	19	22.2	22.2	25.4	28.6	28.6	31.8	34.9	34.9	38.1	41.2	44.5	44.5	50.8
H	145	170	182	200	216	320	275	332	385	455	580	670	750	820	1109
kb	38	51	64	76	102	127	152	200	248	298	327	375	419	464	591
Aprox.wt.å	33.85	42	62.55	65	157	233.5	274	472	692	875	1270	1346	2080	2746	4275

DIMENSIONAL DATA CLASS-900

DN	40	50	80	100	150	200	250	300	350	400
NPS	1 ½	2	3	4	6	8	10	12	14	16
L	305	368.3	381	457.2	609.6	736.6	838.2	965.2	1029	1130
L1	305	368.3	381	457.2	609.6	736.6	838.2	965.2	1029	1130
L2	305	672	384	460	613	740	841	968	1039	1140
kD	178	216	241.3	292.1	381	470	546.1	609.6	641.4	704.9
T	31.8	38.1	38.1	44.5	55.6	63.5	69.9	79.4	88.9	88.9
K(PCD)	124	165.1	190.5	235	317.5	393.7	469.9	533.4	558.8	616
n	4	08	08	08	12	12	16	20	20	20
kd	28.6	25.4	25.4	31.8	31.8	38.1	38.1	38.1	41.1	44.4
H	188	257	302	340	419	430	550	645	641	780
kb	38	47.5	73	98.3	146	190.5	238	283	311	356
Aprox.wt.å	47.7	94.45	128	214.5	388.5	645	1431	1790	2464	3080

DIMENSIONAL DATA CLASS-1500

DN	50	80	100	150	200	250	300	350
NPS	2	3	4	6	8	10	12	14
L	368.3	470	546	705	832	990.6	1130.3	1257.3
L1	368.3	470	546	705	832	990.6	1130.3	1257.3
L2	371	473	549	711	842	1001	1147	1277
kD	216	266.7	311.1	393.7	482.6	584.2	673.1	749.3
T	38.1	47.7	54	82.6	92.1	108	123.9	133.4
K(PCD)	165.1	203.2	241.3	317.5	393.7	482.6	571.5	635
n	08	08	08	12	12	12	16	16
kd	25.4	31.8	35	38.1	44.5	50.8	53.8	60.4
H	300	450	500	600	700	800	950	1020
kb	48	70	92	137	178	222	264	289
Aprox.wt.å	72	104.8	128.6	330.8	----	----	----	----

NOTE: The above data is subject to change without notice due to our continuing product improvement program. (©WEIGHT GIVEN IN KGS)

Flanges as per ASME B16.5. Butt Weld Ends as per ANSI B 16.25.

TEST PRESSURES

CLASS	SHELL TEST (HYDROSTATIC)		SEAT TEST HYDROSTATIC	
150	30 Bar	435 Psi g	22 Bar	319 Psi g
300	77 Bar	1102 Psi g	57 Bar	780 Psi g
600	154 Bar	2175 Psi g	113 Bar	1595 Psi g
900	230 Bar	3350 Psi g	169 Bar	2451 Psi g
1500	384 Bar	5568 Psi g	282 Bar	4075 Psi g