

# Standard Construction

## Standard Type Valve

**Hama Engg** Standard type valve has its integral operating shank at the large end of the taper plug. The plug is seated by means of forces applied through the gland packing housed in the cover which also seals the shank against leakage.

To prevent damage to the packing where it would otherwise rub on the top of the plug, it bears on a metal shim which is clamped between the body and the cover. This reduces friction between the plug and the packing and also acts as a separate and very effective seal against leakage of the line fluid into the packing space.

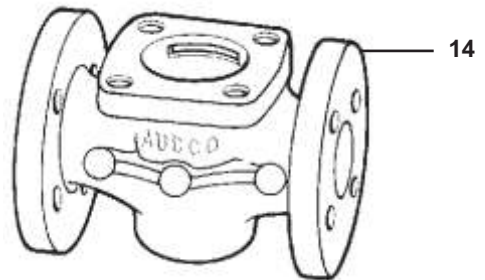
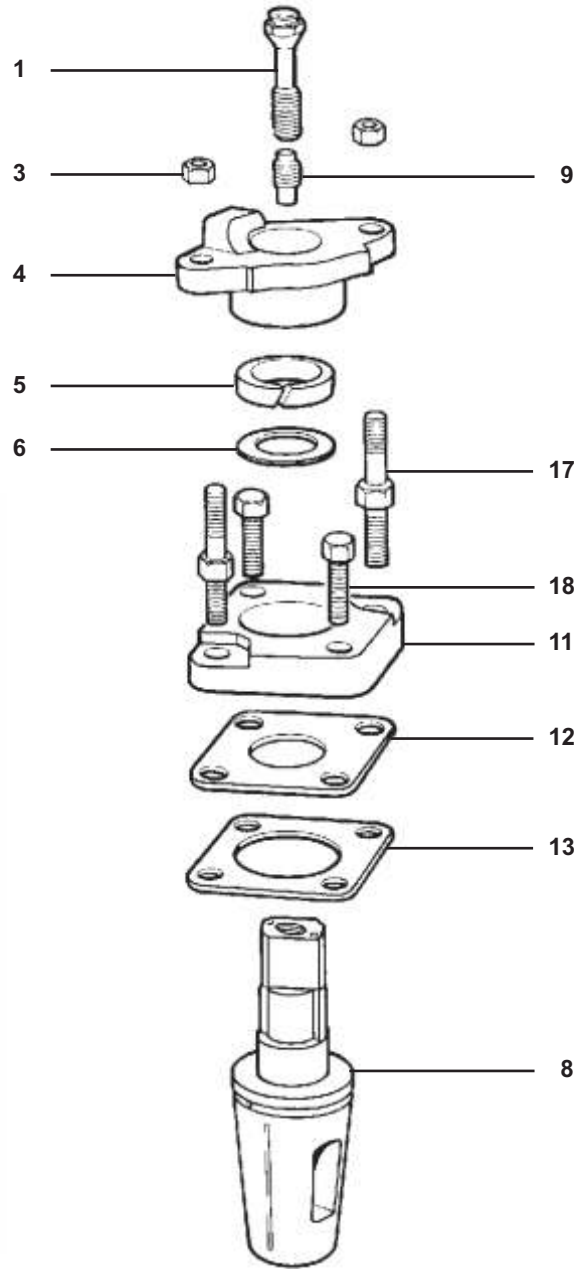
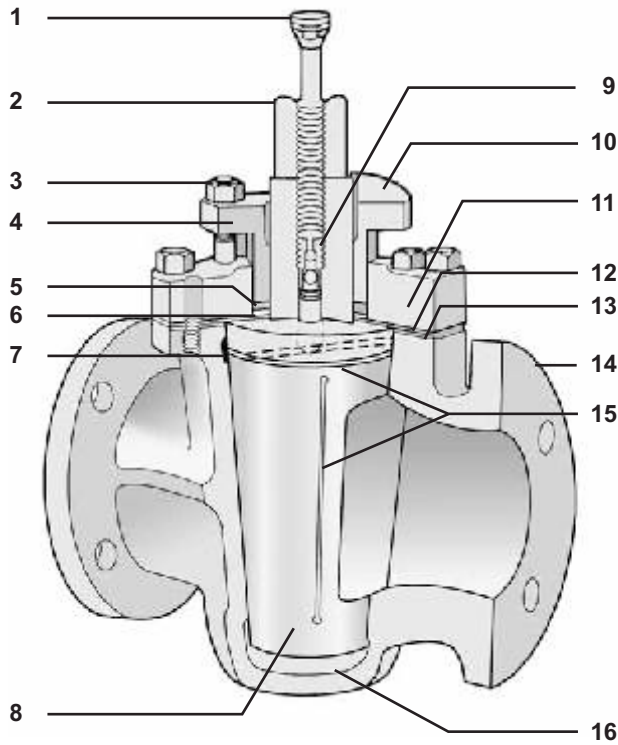

- |                      |                    |
|----------------------|--------------------|
| 1 Sealant Injector * | 10 Stop            |
| 2 Indicator          | 11 Cover           |
| 3 Gland Nuts         | 12 Shim            |
| 4 Gland              | 13 Gasket          |
| 5 Gland Packing      | 14 Body            |
| 6 Packing Ring       | 15 Sealant Grooves |
| 7 Sealant Duct       | 16 Sealant Chamber |
| 8 Plug               | 17 Gland Studs     |
| 9 Check Valve        | 18 Cover Bolts     |

\* Sealant Screw (up to 40mm)

# PLUG VALVE (FLANGE END)

## TECHNICAL DATA

TESTING STD. BS 5146

END CONNECTIONS FLANGED AS PER ANSI B 16.5 150#

FACE TO FACE AS PER ANSI B16.10

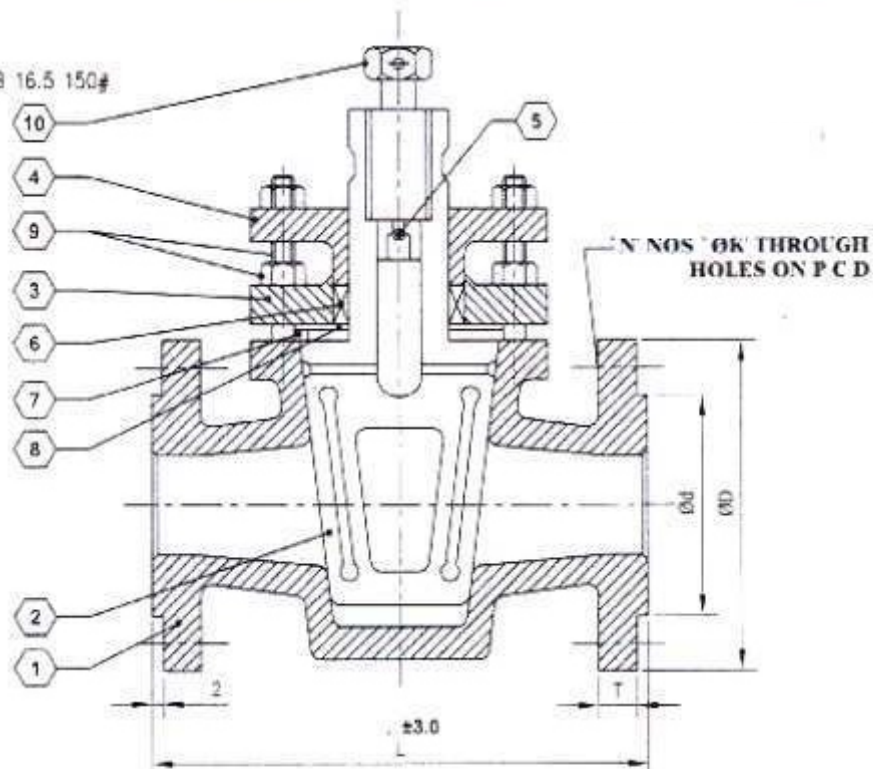

CLASS - 150

SIZE	L	ØD	Ød	PCD	T	N	K
15	121	95	35	60	11.1	4	14
20	121	102	43	70	12.7	4	14
25	141	108	51	79	11	4	16
40	165	127	73	98	14	4	16
50	178	152	92	121	16	4	19
65	190	178	105	140	17	4	19
80	203	191	127	152	19	4	19
100	229	229	157	191	24	8	19
150	267	279	216	241	25	8	22
200	292	342	270	298.4	28.5	8	22
250	330	406	324	362	30	12	25

ALL DIMENSION ARE IN MM

No.	PART NAME	MATERIAL	QTY.
1	BODY	C.I. / CS / CF8 / CF8M	01
2	PLUG	C.I. / CS / CF8 / CF8M	01
3	COVER	C.I. / CS / CF8 / CF8M	01
4	GLAND	C.I. / CS / CF8 / CF8M	01
5	NON RETURN VALVE	M.S. / S.S.	01
6	GLAND PACKING	GRAPHITED ASBESTOS	01
7	BODY GASKET	C.A.F. / P.T.F.E	01
8	DIAPHRAGM	M.S. / S.S. 304 / S.S. 316	01

MW - 11

TABLE "F"

SIZE	L	ØD	PCD	T	N	K
15	121	95	67	9.50	4	14
20	121	102	73	9.50	4	14
25	140	121	87	9.50	4	18
32	153	133	98	12.70	4	18
40	165	140	105	12.70	4	18
50	203	165	127	15.90	4	18
65	222	184	146	15.90	8	18
80	241	203	165	15.90	8	18
100	305	229	190	19	8	18
125	356	280	235	22.20	8	22
150	394	305	260	22.20	12	22

ALL DIMENSION ARE IN MM

CLASS	HYD. TEST PRESSURE BODY	SEAT
150	22 Kg / Cm <sup>2</sup>	16 Kg / Cm <sup>2</sup>

SUITABLE FOR:

STEAM	WATER	OIL	AIR	GAS
●	●	●	●	