

Thermodynamic Steam Traps TD – 55

Description:

MMKE TD 55 is a thermodynamic steam trap with in-built strainer screen and unique three port design. The three port design ensures parallel lifting of the disc and no wearing due to uneven seating of the disc enhancing the life of the trap. Integral Slowdown valve allows online cleaning of strainer screen. Typical applications include main distribution headers, turbine inlets etc.

Sizes & Pipe Connections :

15 NB and 20 NB
Screwed BSPT / NPT and Socket Weld Ends with Slowdown valve.

Note:

1. Available with ASA-150, 300, & 600 weld on flanges on request.
2. Available with IBR certificate

Limiting Conditions :

PMO : Max. Op. Pressure in kg / cm².
TMO : Max. Op. Temperature in Deg. C

Parameter	Screwed end	Socket Weld end
PMO	31.5	55.0
TMO	427.0	450.0
Hyd. Test	63.0	110.0

PMOB-Max.: Operating Back Pressure on outlet should not exceed 80% of inlet pressure.
Min. inlet pressure for satisfactory operation -0.25 kg / cm².

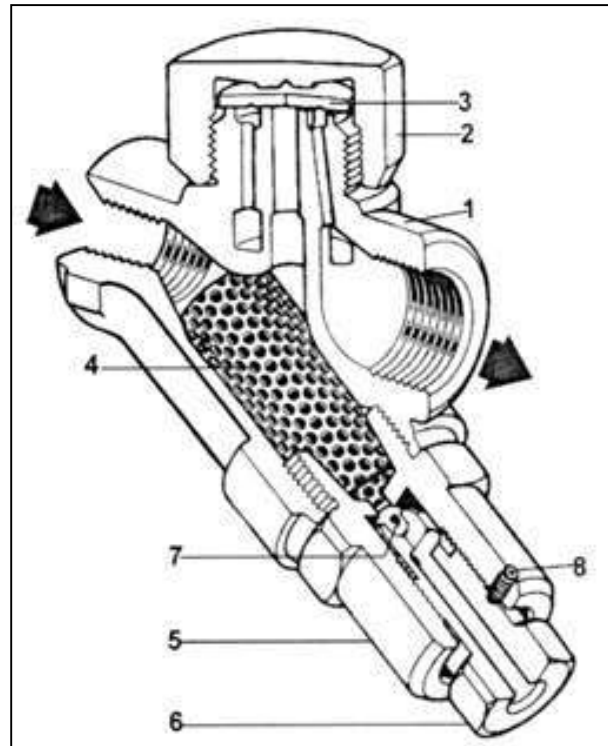

Capacity Chart :

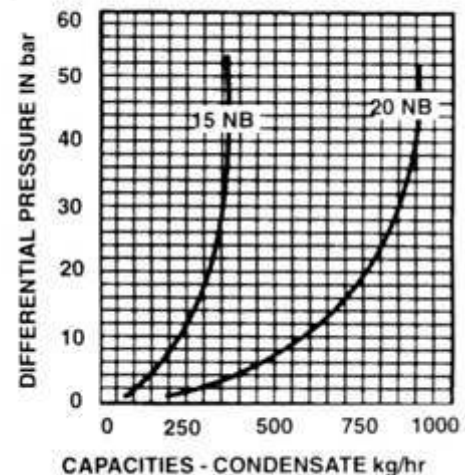

Material:

Sr. No.	Description	Mat.	Standard
1	Body	S.S.	ASTMA 743 Gr.-CA 40
2	Cap	S.S.	ASTMA 743 Gr.-CA 40
3	Disc	S.S.	ASTM A 743 Gr.-CA 40
4	Screen	S.S.	ASTM A 240, Type 304
5	Blowdown Cap	St. Steel type 304	ASTM - A 276
6	Blowdown Screw	St. Steel type 304	ASTM - A - 276
7	Blowdown Valve	St. Steel	AISI440B
8	Grub Screw	Hardened Steel	--

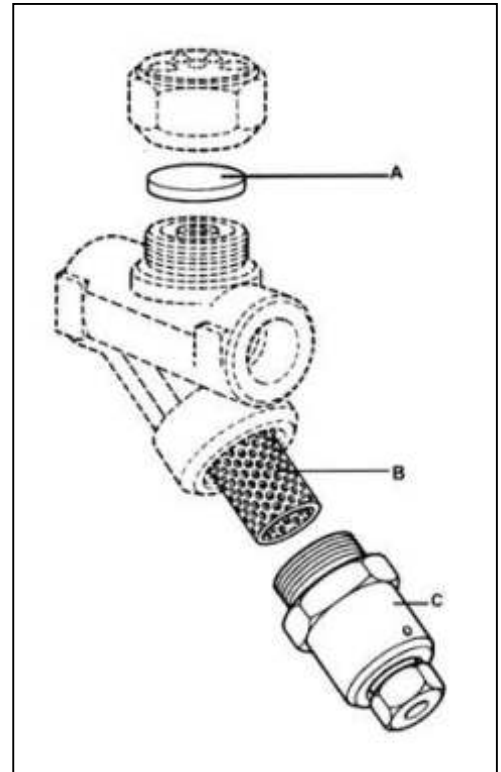

Salient Features:

1. Complete stainless steel construction ensures better mechanical and corrosion resistant properties.
2. The disc and seat are hardened by induction hardening process to about 50 Re to enable withstand continuous water hammering condition.
3. Seat is integral part of the body. and eliminates leakage prone joints and gaskets.
4. Condensate entry below the disc concentric to disc and seat, ensures clean and parallel lift of disc with reference to seat, eliminating any localised uneven wear & tear.
5. An inbuilt strainer screen of adequate large area ensures long and trouble free operation.
6. Three port design ensures proper lifting and seating of the disc and results in uniform wear enhancing life of the steam trap.
7. Integral Blowdown Valve facilitates on line cleaning of strainer screen.

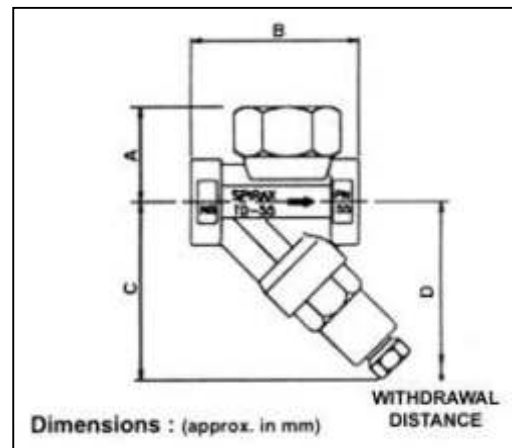

Installation :

Preferably on horizontal pipe line; can be fitted in other position if unavoidable.

Operation of Slowdown Valve.

The slowdown valve has a screw (6) which can be unscrewed with a 19mm A/F spanner to discharge the contents of the strainer screen. To make Blowdown screw (6) operational screw the Grub screw (8) 2 to 3 threads. The Grub Screw (8) will prevent the slowdown screw (6) from disengaging from the slowdown cap (5). Ensure Grub Screw (8) is tightened back. Ensure adequate safety precautions are taken when opening the slowdown valve to atmosphere. Hand protection is a must.

Optional extras:

ISOTUB: An insulating cover on the cap prevent the trap being unduly influenced by excessive heat loss such as when subjected to low outside temperatures, wind, rain etc.

Dimensions : (approx. in mm)

SIZE	A	B	C	D
15&20NB	42	68	78	125

